

# DS1200P<sub>7</sub>XP

## Operation Instructions



## Contents

Setting Up Your Machine	3
Maintenance Procedures	5
Service Intervals	5
Cleaning Procedures	6
Replacing Components	7
Chamber Door Sensors	7
Electrical Box Overview	9
Pneumatic Overview	10
Fault Finding Procedures	11
Cycle Description	13
Electrical Diagrams	14

The instructions and advise in this handbook are designed to let you run and maintain the machine as efficiently and smoothly as possible. If you have any questions regarding any aspect of our machinery, please feel free to contact us at [info@scotnet.com](mailto:info@scotnet.com)

## Setting Up Your Machine

This machine is used in stuffing applications, where pressure is applied before the product is pushed through the tube.

Two tube styles are available, either standard netting tubes, or casing finger tubes.

Although the machines always leave in a clean condition, washing is advised before taking any machine into a food production area. The DS1200P<sub>7</sub>XP can be washed with water (not a high pressure hose). For full cleaning instructions, see the Cleaning Procedures section.

The machine should be positioned on a level surface. When in place, lock the four braked castors to secure the machine.

### (A) Connecting the Machine

The DS1200P<sub>7</sub>XP is powered by 230-volt AC mains electrical supply and compressed air.

#### **Compressed Air Connection:**

The machine comes with 3-4 metres of braided air hose. This is at the rear of the machine. Connect the compressed air supply to this. The machine should have the air pressure set at the regulator between minimum 5 BAR and 8 BAR maximum. At 5.5BAR, the machine uses approximately 70ft<sup>3</sup> or 2000 litres of compressed air per minute. It is essential that the air supply is clean and dry. Note components that fail due to water damage are not covered by the warranty.

#### **Electrical Connection:**

The machine comes with approximately 3 metres of cable, which can be shortened as required. Connect the machine to a 230v single phase supply.

### (B) Only for Option Pack AWI, Machine with Automatic Water Injection

If your machine has AWI, it also needs to be plumbed into a **drinking water supply**. The machine comes with a length of 10mm hose for you to connect to your supply. The water should be at mains pressure. As an option, if mains water is not available, you can use the external pressurised water bottle instead.

### **(C) Fitting the Chambers and Tubes**

Isolate the machine from both the compressed air and electrical supply.

On this machine, the same size of chamber and tube must be used on each side.

Before beginning, ensure you have 2 tubes, 2 chamber bottoms, 2 pistons, 4 rings and one chamber top that all match in size.

This instruction assumes the machine is empty, i.e. has none of the above fitted. If tubes etc are fitted, follow this procedure in reverse to remove them.

Open both chamber doors, and slide the lid fully to one side.

- Insert a Chamber Top and secure using the locating pins on the lid. NOTE; ensure cut out section of chamber top is pointing towards the rear of machine.
- Screw the Pistons onto cylinder rod ends and gently nudge nylon rings into position.
- Slide the Chambers onto Press Plates; ensure chamber sliders are properly positioned onto press plates. NOTE; not sitting on press plates, slotted on
- Fit both Tubes to the machine.
- Reconnect the electric and compressed air supplies.

### **(D) Running the Machine**

The machine is fitted with an emergency stop at each side. Once pressed, these require a quarter turn to release them. If any of the safety circuit is broken e.g. a tube out, emergency stop pressed, the red LED will be illuminated and the HMI will inform you what the fault is. Once the machine is safe and ready to run the green LED will be illuminated.

Sliding the lid from one chamber to the other operates the machine. Once closed, the lid will lock until the machine has completed its cycle.

### **(E) Adjusting the Automatic Water Injection (Only for machines fitted with AWI)**

Use the HMI to select water On or Off. The duration of the spray can also be adjusted.

### **(F) Anti Jam Technology**

The machine is fitted with a system that detects if it has jammed, normally because a product is too large. If this occurs, the machine will count out 5 seconds. If the machine has jammed while pressing; the cylinders will retract allowing you to open the lid and remove blockage, if the machine has jammed during the stuffing cycle the press will retract first and then the pusher cylinder will return to it's home position.

#### **Important Note:**

**Only use netting tubes & chambers designed for use with the DS1200P<sub>7</sub>XP stuffing system. If in doubt, contact our Service Desk.**



## Maintenance Procedures

### Daily Checks:

1. Check the auto drain filter regulator for water collection. Manually drain if required. (This should drain automatically from pipe exiting the enclosure.)
2. Check the cylinder fixings are properly secured.
3. Check the operation of the safety circuit.  
First remove each tube in turn. Each time one is removed, the red LED will be illuminated and an audible dump of air should be heard, the machine should not function, the display panel should indicate which parts of the safety circuit has been broken. Do the same check with each chamber door and e-stop button.
4. Lubricate the lid slides with a food safe lubricant.
5. Ensure area under tube sensor switch guard is clean.
6. Ensure product juice is not allowed to stand on cylinder end caps, this can cause corrosion and failure of neck seals.
7. Check the machine functions, by moving the lid from side to side.

**NB If in doubt about anything, contact our Service Desk.**

### Weekly Checks:

1. Check air pressure setting is between minimum 5 Bar and 8 Bar maximum.
2. Check all nuts and bolts for security, tighten if required.
3. Lubricate press cylinder end caps with food safe grease to repel product juice.
4. Check cylinder press plates are tight, tighten if required.

**NB If in doubt about anything, contact our Service Desk.**

## Service Intervals

After installing the machine, we recommend that it is inspected by the installation engineer after:

- One Week
- One Month
- As required after this. We do not recommend leaving any machine for more than 6 months between services. The daily and weekly checks above must be carried out between services.
- Failure to service the machine in accordance with our recommendations invalidates the warranty.

## **Cleaning Procedures**

Before cleaning the machine, remove the tubes, chambers, pistons, nylon rings and chamber top from the machine. For instructions on this see section C. 'Fitting the Chambers and Tubes'. To ease the cleaning process you can put all of the removable parts in a bulk container of hot water.

When the parts are removed, and the machine is isolated from its supplies, pull each of the usher rods out, and clean the rods. When finished, push the rods back to their 'Home' positions.

The machine can now be cleaned with low pressure hoses and a hand brush

Do not spray water onto the HMI.

Once cleaned, replace all of the parts.

## Replacing Components

Some components on the DS1200P7XP require setting up before fitting replacements to the machine.

Below, each component in the machine is pictured, with additional comments on how to replace them where required.

---

### Tube In Position Sensors



#### **Tube in Position Inductive Proximity Detectors (IPD)**

To detect when each tube is in position, 2 inductive proximity detectors are used. On each chamber, there are two Normally Open IPD's. When replacing sensors please ensure they are flush fitted to prevent tube baseplate hitting sensor surface.

## Chamber Lid Sensors

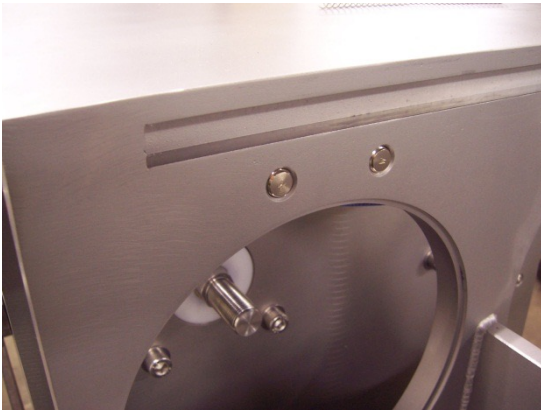

The lid sensors are easily accessible and quick to replace, remember and put food safe lubricant in the connector when changing to repel water.



## Door Sensors

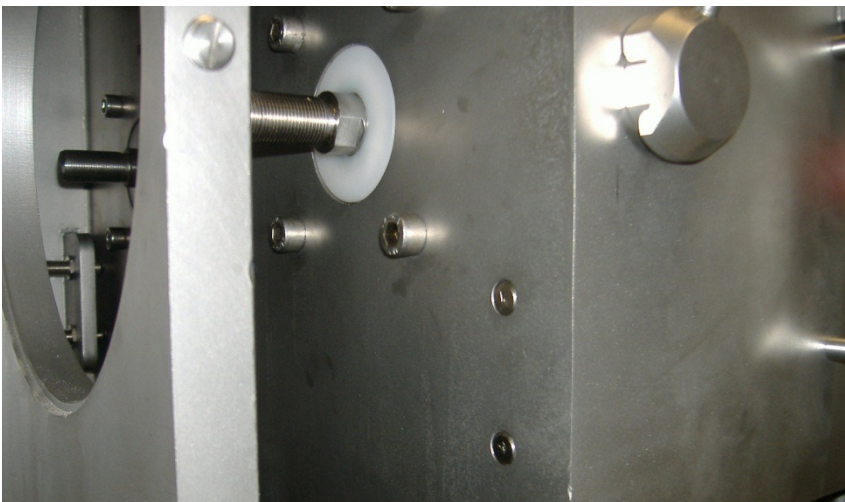

The door sensor can be accessed by removing the pusher cylinder from inside the machine. Make sure and remove the tube position sensors from the cylinders before removing the cylinders. Once removed you can then remove the desired sensor and replace.



## Electrical Box Overview



All connections to the electrical cabinet are via pre-wired plugs. Both the plugs and the cabinet are clearly marked for easy identification.

## Pneumatic Overview

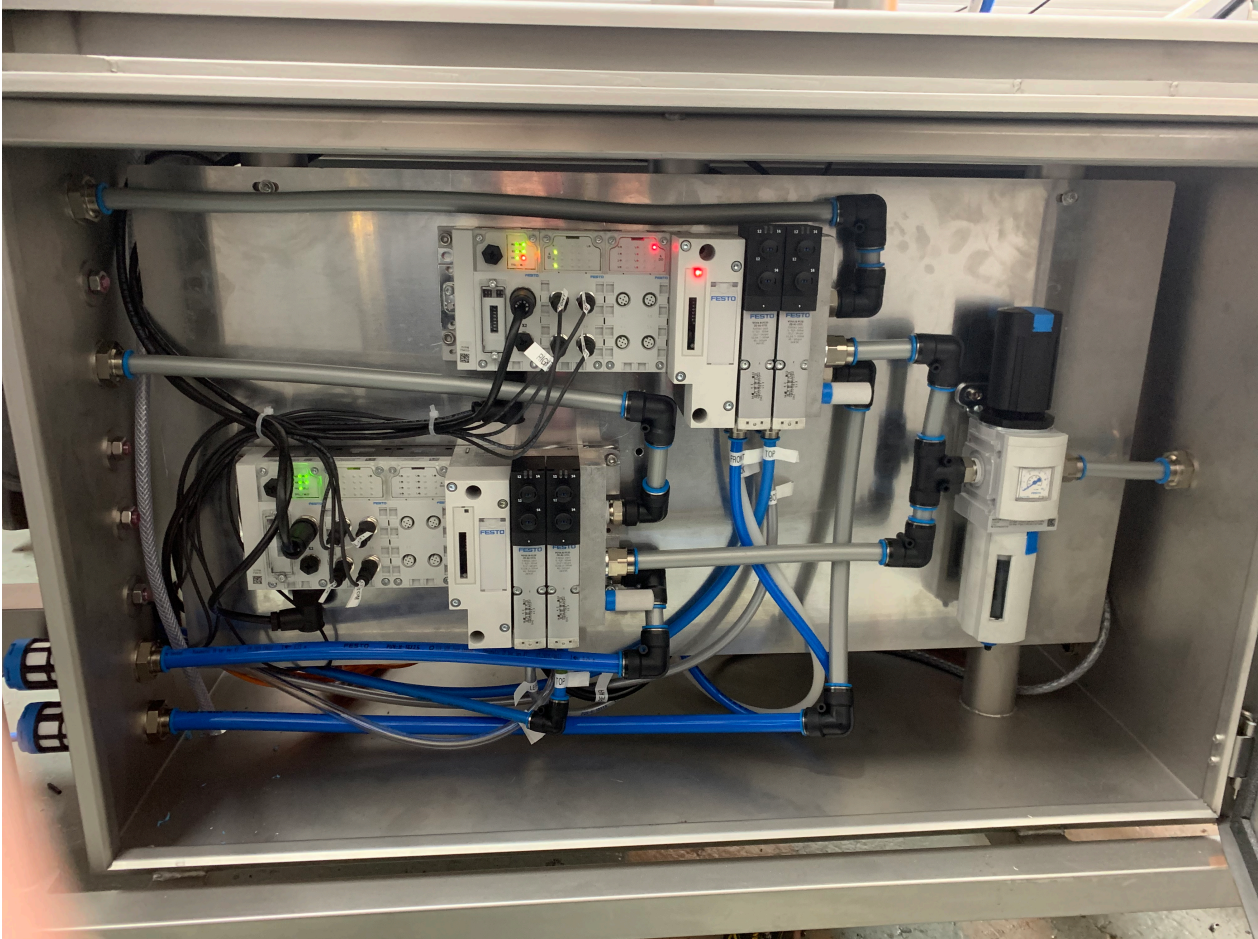

The pneumatics are split with one valve black for the left hand side of the machine and one for the right. All pipes and connections are clearly marked with colour coded tubing being used to make identification even easier.



## Fault Finding Procedures

### Information Screen

The machine is fitted with a clear easy to read screen which highlights all doors and safety guards.

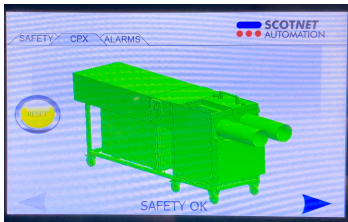

Machine ready to run.

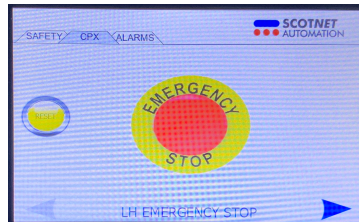

Emergency stop pressed.

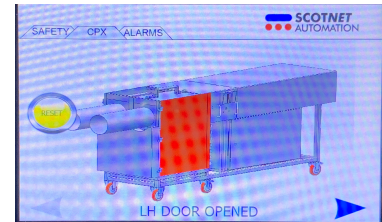

Left hand door opened.

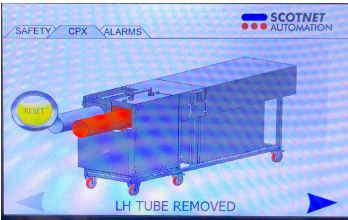

Left hand tube removed.

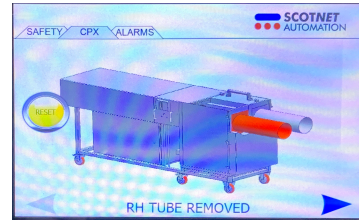

Right hand tube removed.

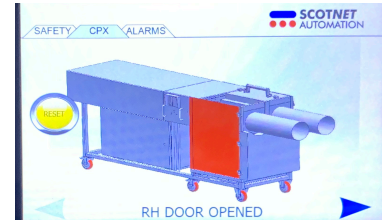

Right hand door open.

### Machine Fails to Operate

Check the air pressure at the regulator. It should be set between minimum 6 Bar and 8 Bar Maximum (see 'Setting Up the Machine' section)

Check both tubes are located correctly on the machine.

Check both emergency stops are released and in the safe position. (Red LED and Allen Bradley Touch Panel will inform you of any breaks in the emergency stop circuit).

Ensure reset button has been pressed. (green LED will be illuminated)

Check that the filter regulator is free from water.

Check Isolator is in the 'On' position, and the electrical supply is connected.

Check the chamber doors are closed and latched.

There are some fuses in the Electrical Box inside the machine. Check that these have not blown. (See electrical drawing to identify fuses)

Check the relevant Omron relays light up when the various doors etc are opened and closed. (See relay information sheet)

For all other faults, contact our Service Desk.

### **Automatic Jam Detection**

The machine is fitted with Automatic Jam Detection. Therefore if a product is placed in the chamber, and the chamber lid slid over, the cycle is started as normal. If the machine does not complete its cycle in a pre set time, it will detect this, and return the piston to its start position, and unlock the chamber door, so it can be opened, and the jam removed.

### **Lid Will Not Open**

If lid will not open, the machine has not completed its cycle (jammed). The machine will automatically count to 5 seconds in this case and will then reset automatically.

If the bottom chamber is jammed in the up position check the plc to make sure you are not getting a false signal from the bottom cylinder sensor. (See electrical drawings for inputs / outputs)

### **Emergency Stop Pressing / machine reset**

When either emergency stop is pressed, the machine will stop wherever it is in its cycle.

When the emergency stop is reset you must then press the reset button on the HMI to reset the machine.

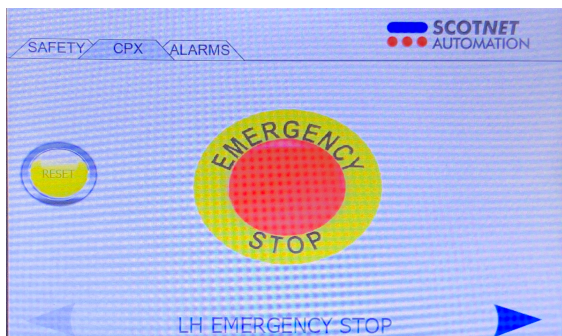

If there are any other problems, please contact our SCOTNET Automation Service Desk on: +44 (0) 1355 237041 for assistance.



## Cycle Description

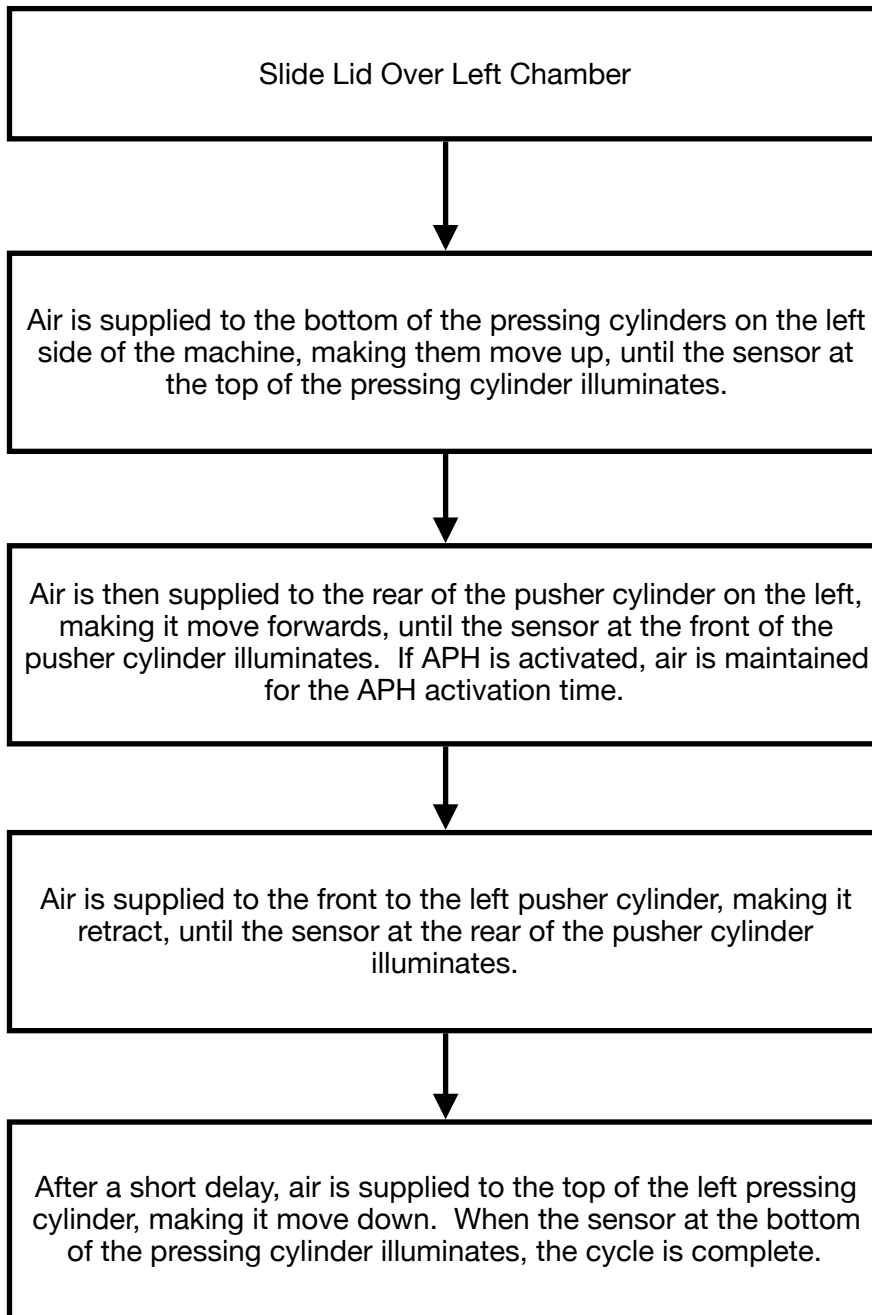

The Right Hand side is identical.

# Electrical Diagrams

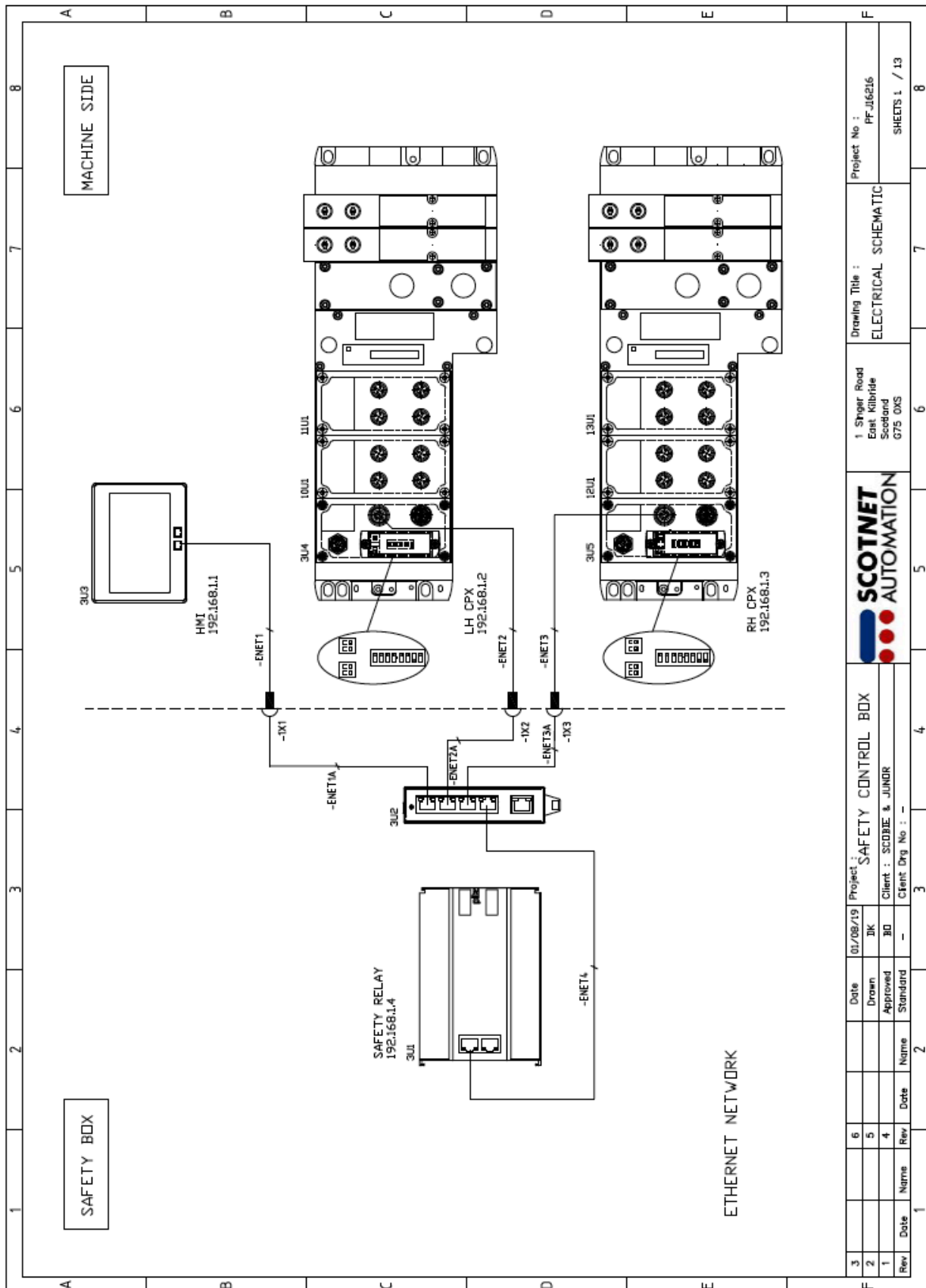

3	Rev	Date	Name	Rev	Date	Name	3	Client Drg No : --		1 Singer Road East Kilbride Scotland G75 0XS	Drawing Title : ELECTRICAL SCHEMATIC	Project No : PF-J16216	SHEETS : / 13 8
2	Approved	Standard	4			4	Client : SCODIE & JUNIOR						
1	Drawn	JK	5			5							

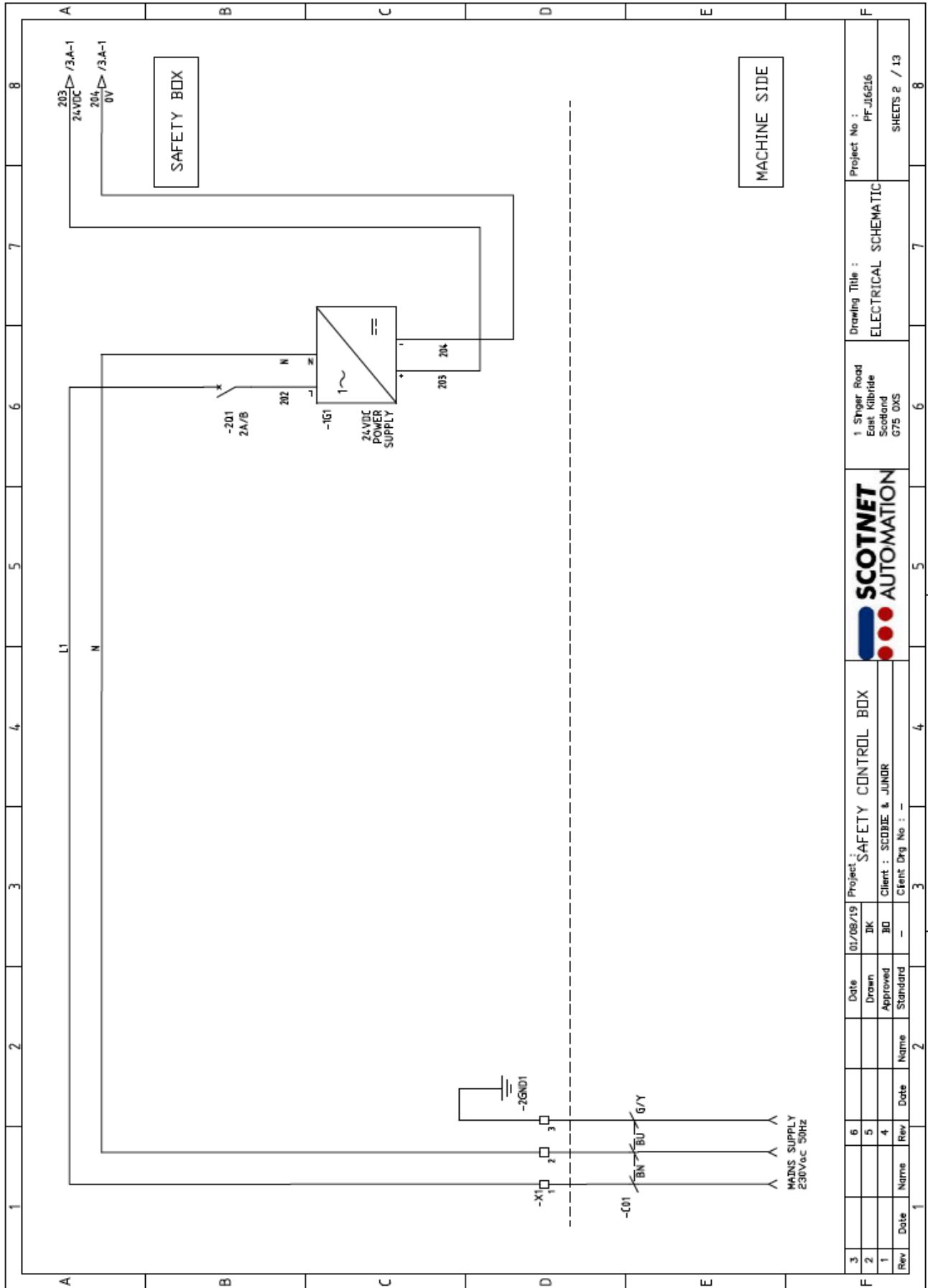

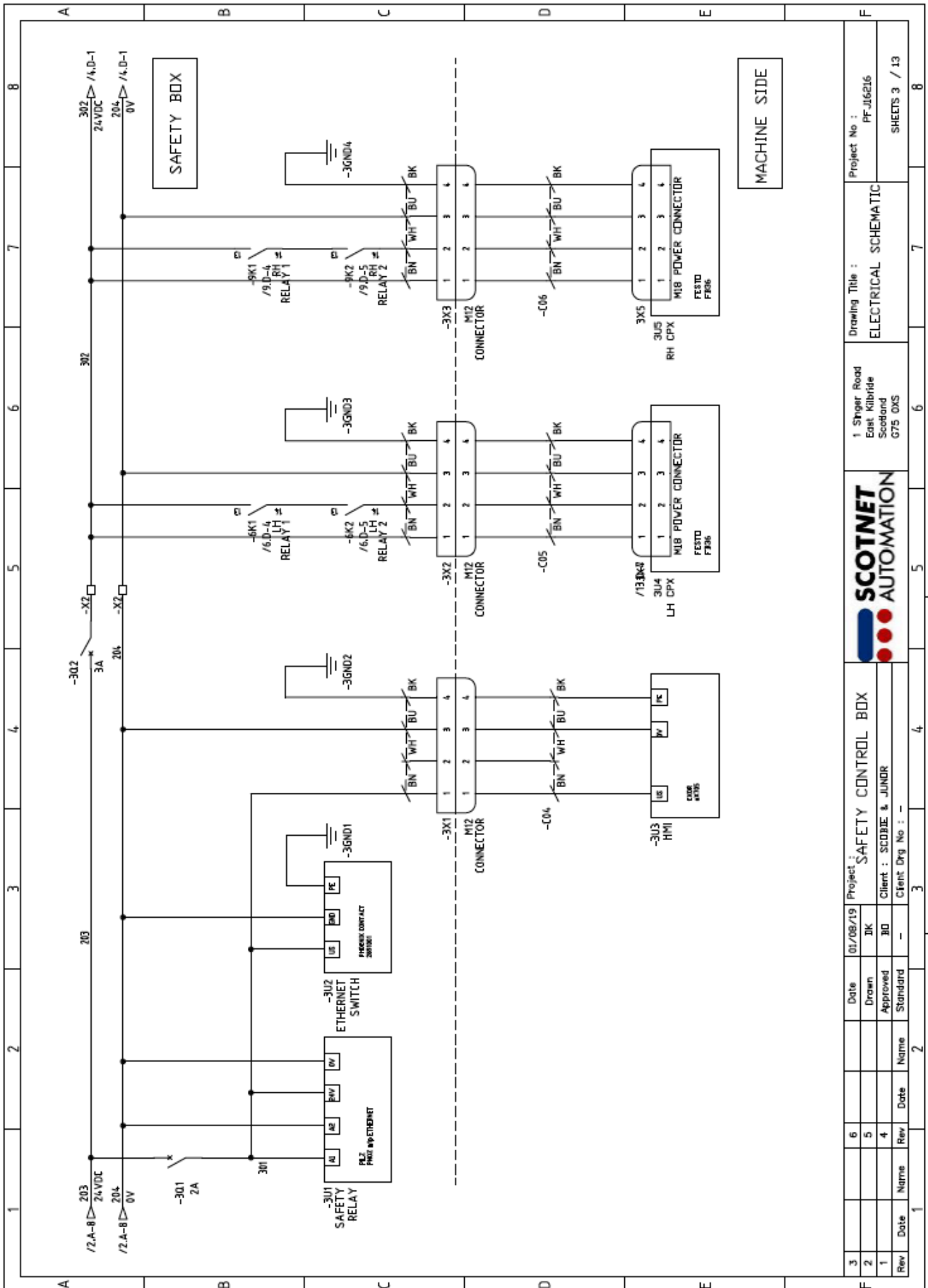

Rev	Date	Name	Rev	Date	Name	Rev	Date	Name
3			6					
2			5					
1			4					

Project: SAFETY CONTROL BOX		Project: SAFETY CONTROL BOX		Project: SAFETY CONTROL BOX		Project: SAFETY CONTROL BOX	
Date	01/08/19	Date	01/08/19	Date	01/08/19	Date	01/08/19
Drawn	IK	Drawn	IK	Drawn	IK	Drawn	IK
Approved	BD	Approved	BD	Approved	BD	Approved	BD
Standard		Standard		Standard		Standard	
Name		Name		Name		Name	
Client	SCOBIE & JUNIOR	Client	SCOBIE & JUNIOR	Client	SCOBIE & JUNIOR	Client	SCOBIE & JUNIOR
Client Drg No	-	Client Drg No	-	Client Drg No	-	Client Drg No	-

Drawing Title: ELECTRICAL SCHEMATIC		Drawing Title: ELECTRICAL SCHEMATIC		Drawing Title: ELECTRICAL SCHEMATIC		Drawing Title: ELECTRICAL SCHEMATIC	
Project No: PF.16216		Project No: PF.16216		Project No: PF.16216		Project No: PF.16216	
SHEETS 3 / 13		SHEETS 3 / 13		SHEETS 3 / 13		SHEETS 3 / 13	

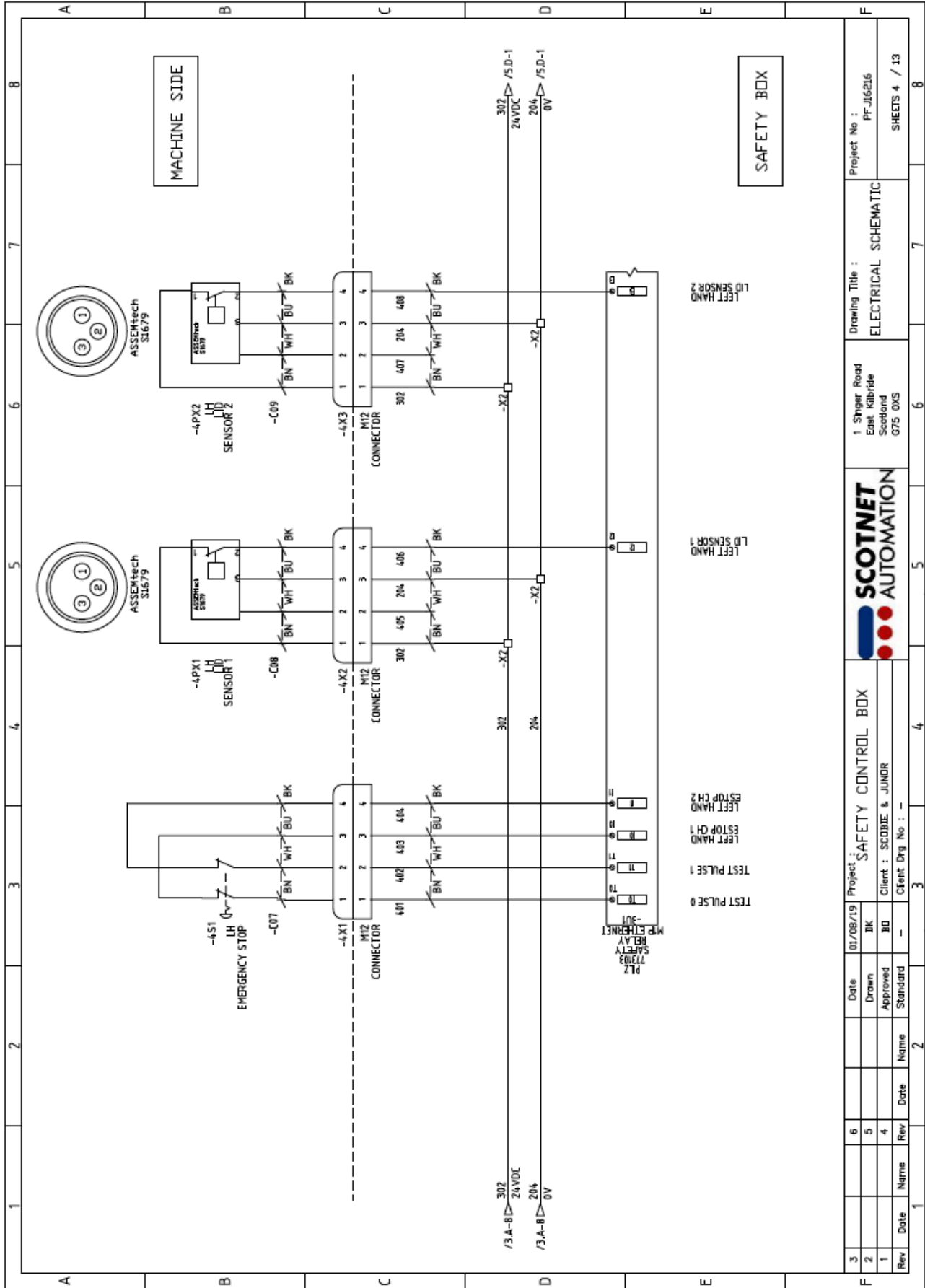

Project No : PF-J16216  
 SHEETS 4 / 13

Drawing Title :  
 ELECTRICAL SCHEMATIC

1 Singer Road  
 East Kilbride  
 Scotland  
 G75 0XS



Project : SAFETY CONTROL BOX  
 Client : SCDBIE & JUNIOR  
 Client Drg No : --

Rev	Date	Name	Rev	Date	Name
3			6		
2			5		
1			4		

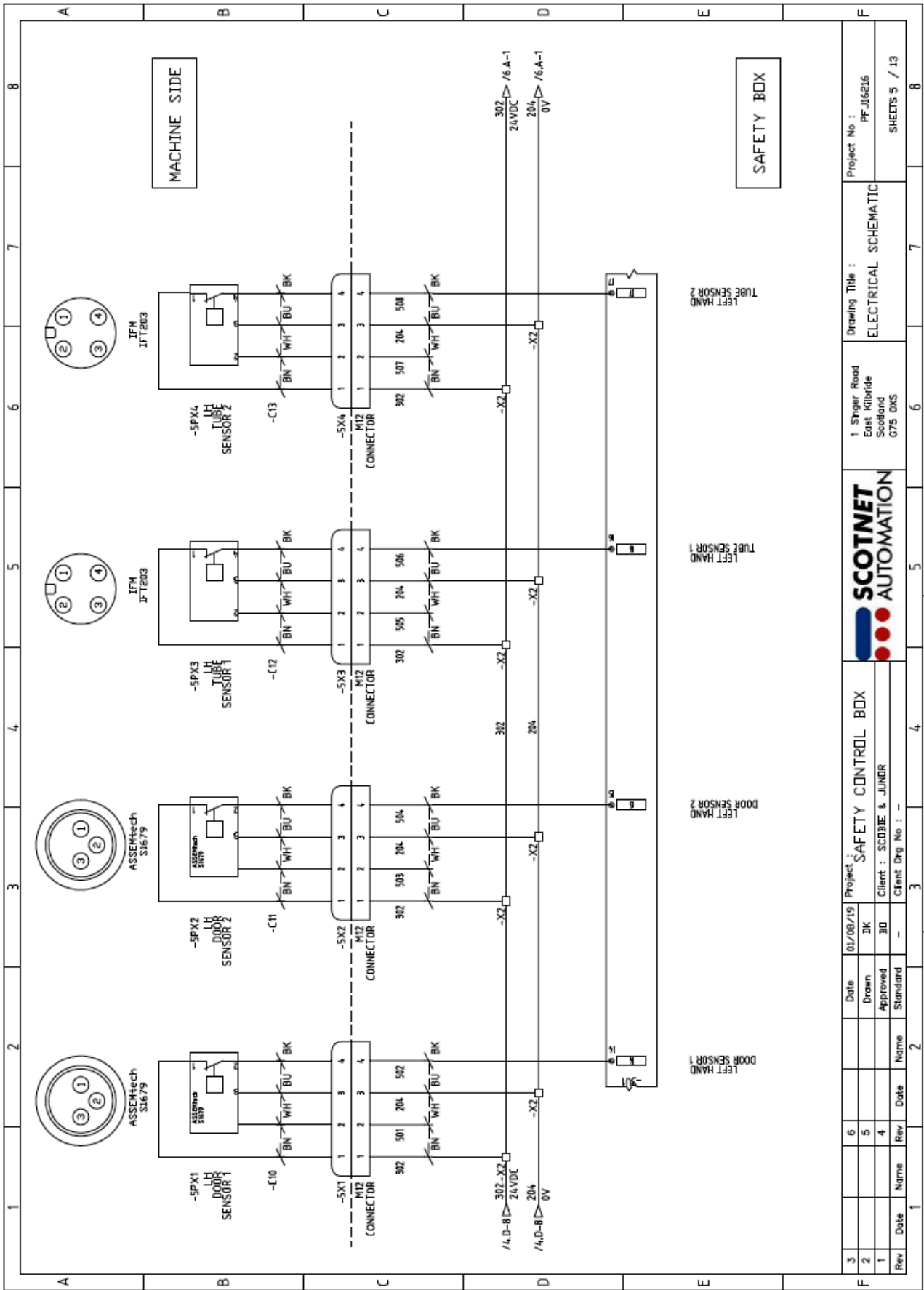

3	Date	01/09/19	Project	SAFETY CONTROL BOX		1 Singer Road East Kilbride Scotland G75 0XS	Drawing Title : ELECTRICAL SCHEMATIC	Project No : PF-J16216
2	Drawn	DK						
1	Approved	JD	Client : SCDBIE & JUNOR					
Rev	Date	Name	Rev	Date	Name	Client Drg No : -	SHEETS 5 / 13	

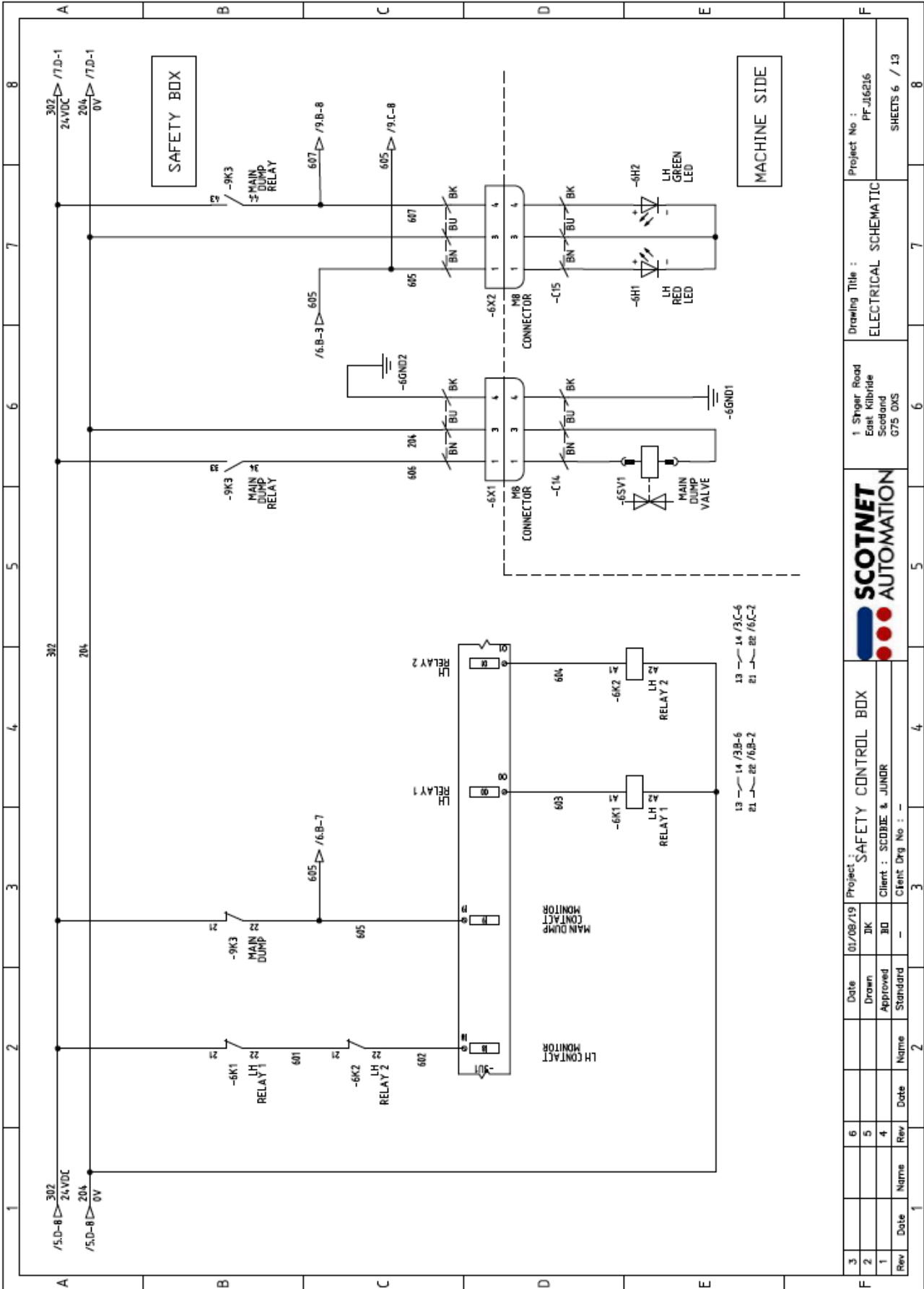

3		6		01/08/19	Project: SAFETY CONTROL BOX	SCOTNET AUTOMATION	1 Singer Road East Kilbride Scotland G75 0XS	Drawing Title: ELECTRICAL SCHEMATIC	Project No.: PF-J16216	8
2		5		JK						7
1		4		Standard	Client: SCOBIE & JUNIOR					6
Rev	Date	Name	Rev	Date	Client Drg No: -					5
			2							4
			1							3
										2
										1

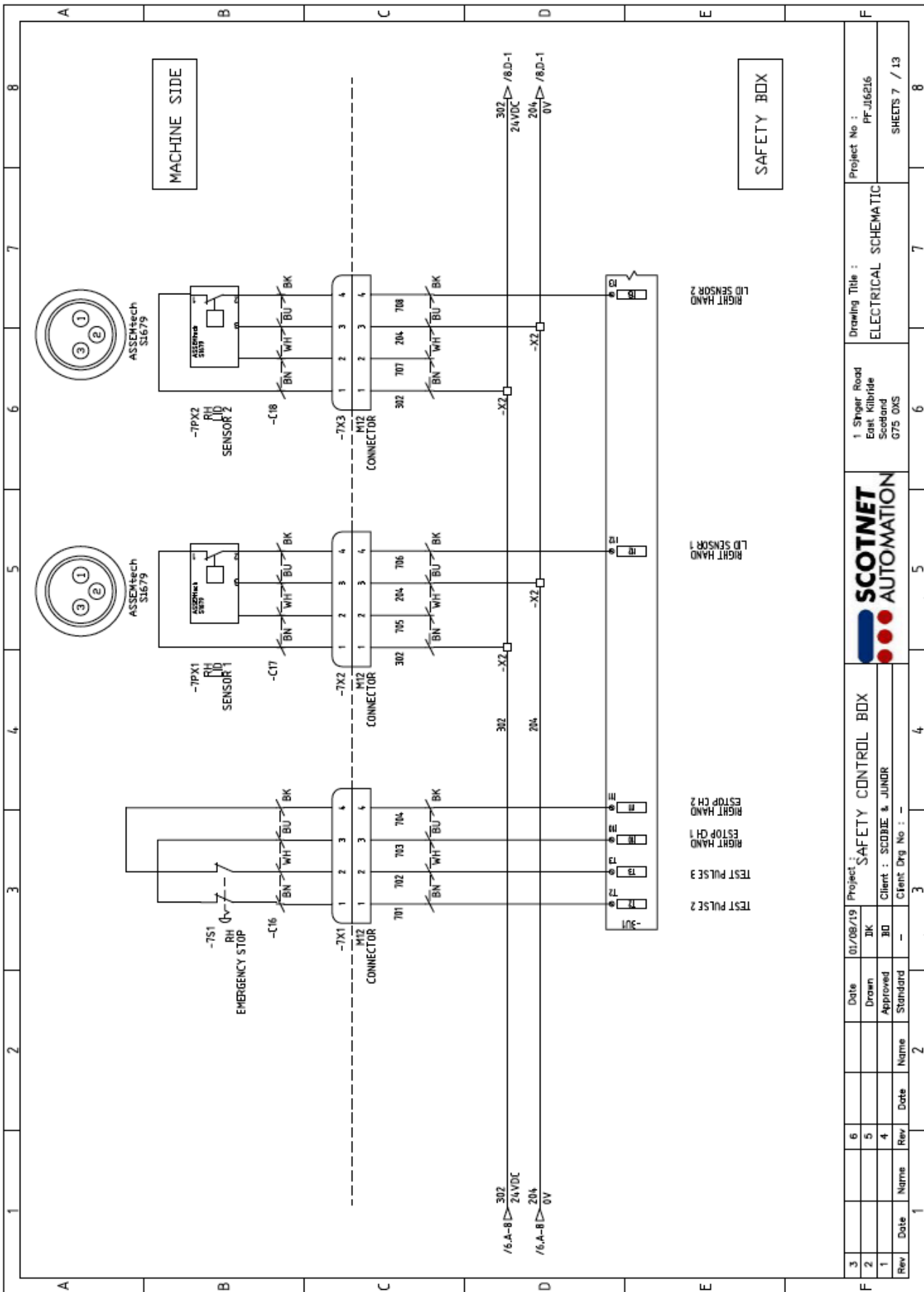

3	Date	01/08/19	Project	SAFETY CONTROL BOX	Client	SCOBIE & JUNDR	Client Drg No	---	
2	Drawn	ZJK	Project	1 Singer Road	East Kilbride	Scotland	G75 0XS	---	
1	Approved	---	Drawing Title	ELECTRICAL SCHEMATIC				Project No	PF-J16216
Rev	Date	Name	Rev	Date	Name	Rev	Date	Name	
1	---	---	4	---	---	4	---	---	
2	---	---	5	---	---	5	---	---	
3	---	---	6	---	---	6	---	---	
4	---	---	7	---	---	7	---	---	
5	---	---	8	---	---	8	---	---	
6	---	---	SHEETS 7 / 13						---



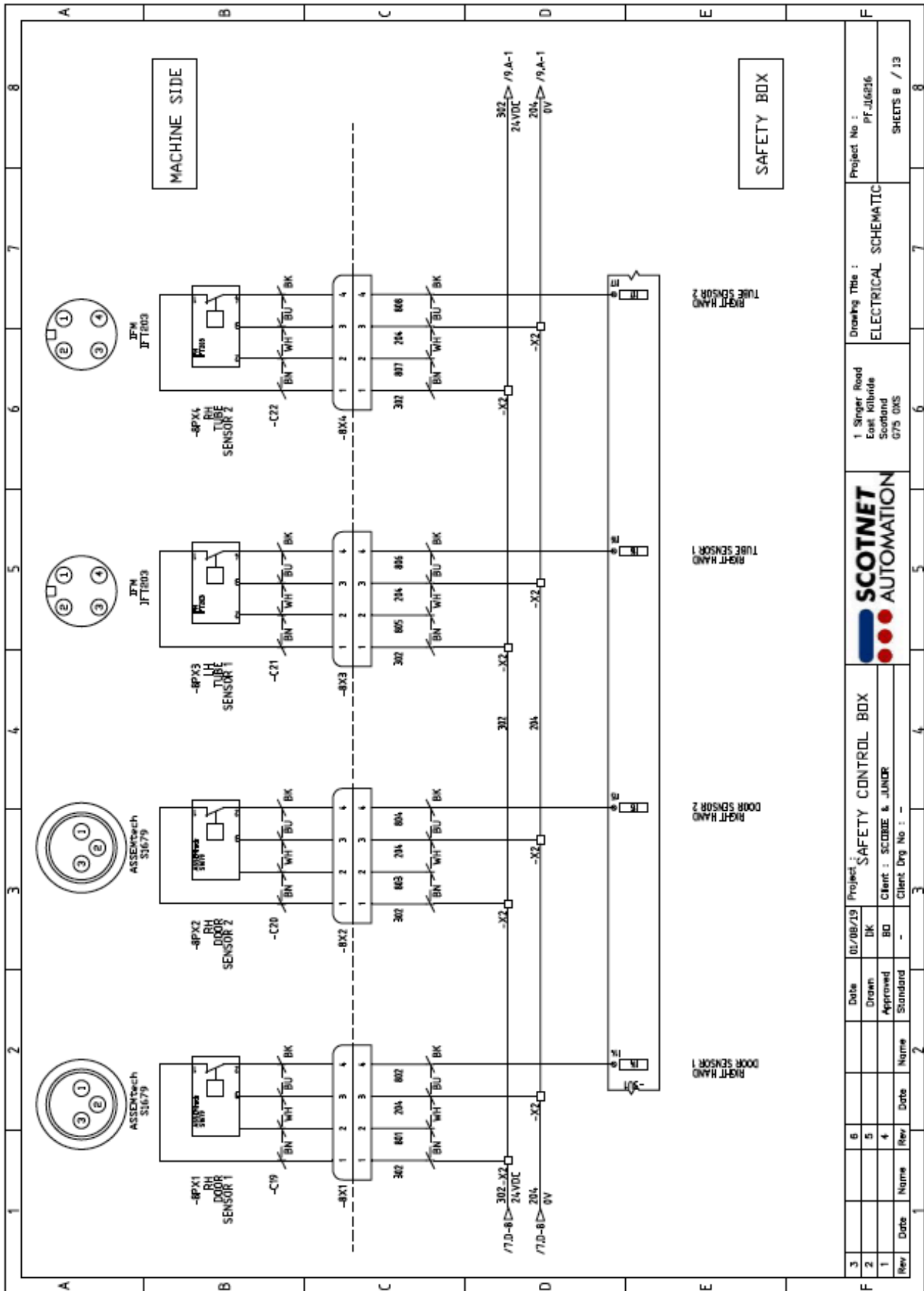

3	Date	01/08/19	Project	SAFETY CONTROL BOX		1 Singer Road East Kilbride Scotland G75 0XS	Drawing Title : ELECTRICAL SCHEMATIC	Project No : PF-J66216
2	Drawn	DK	Client	SCORBE & JUNIOR				
1	Approved	BD	Client Drg No	-	SHEETS 8 / 13			
Rev	Date	Name	Rev	Date	Name			





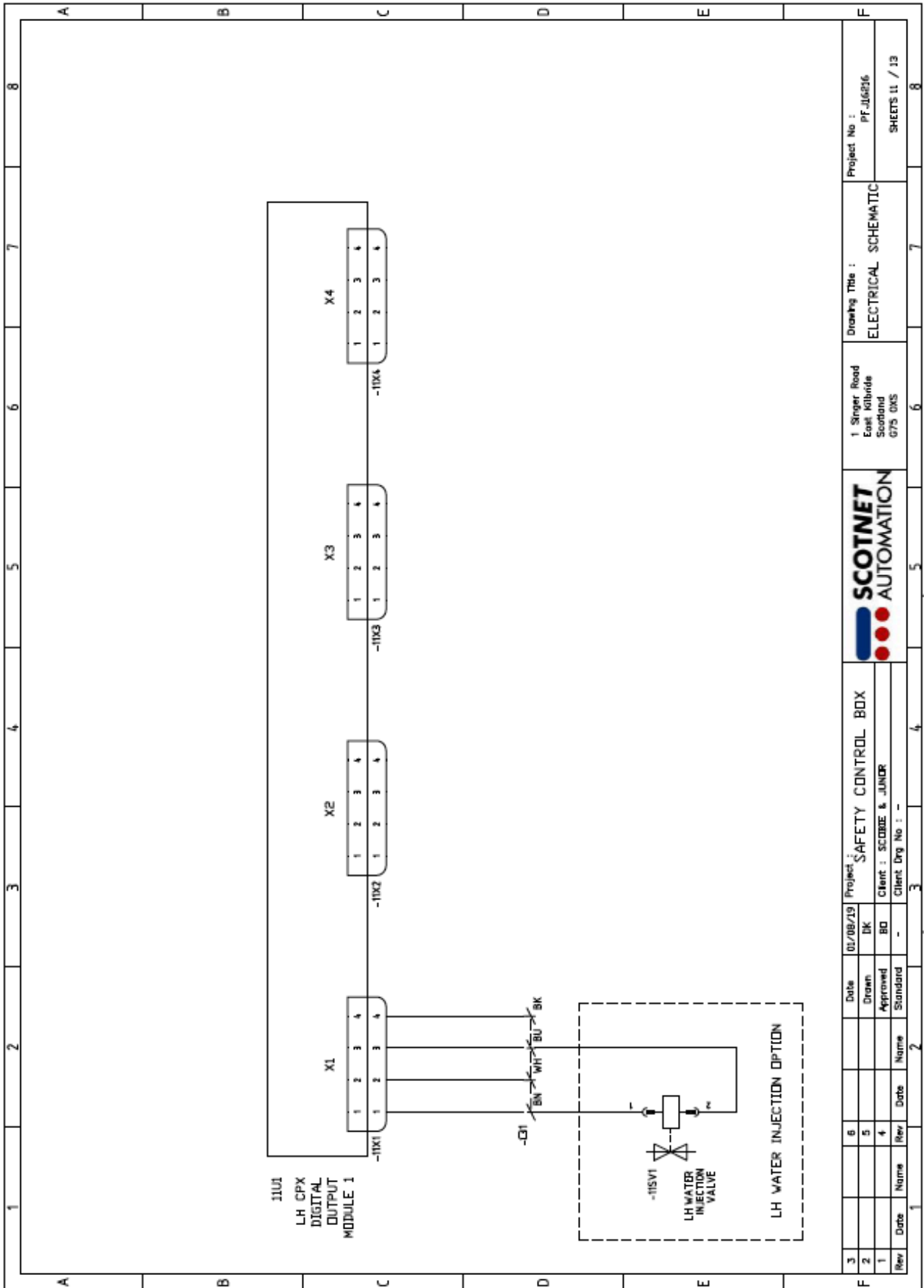

Project No : PF-J16216
SHEETS 11 / 13

Drawing Title :  
**ELECTRICAL SCHEMATIC**

1 Singer Road  
 East Kilbride  
 Scotland  
 G75 0XS



Project : SAFETY CONTROL BOX  
 Client : SCOBIE & JUNIOR  
 Client Drg No : -

Date	Drawn	Approved	Standard
01/08/19	DK	BD	-

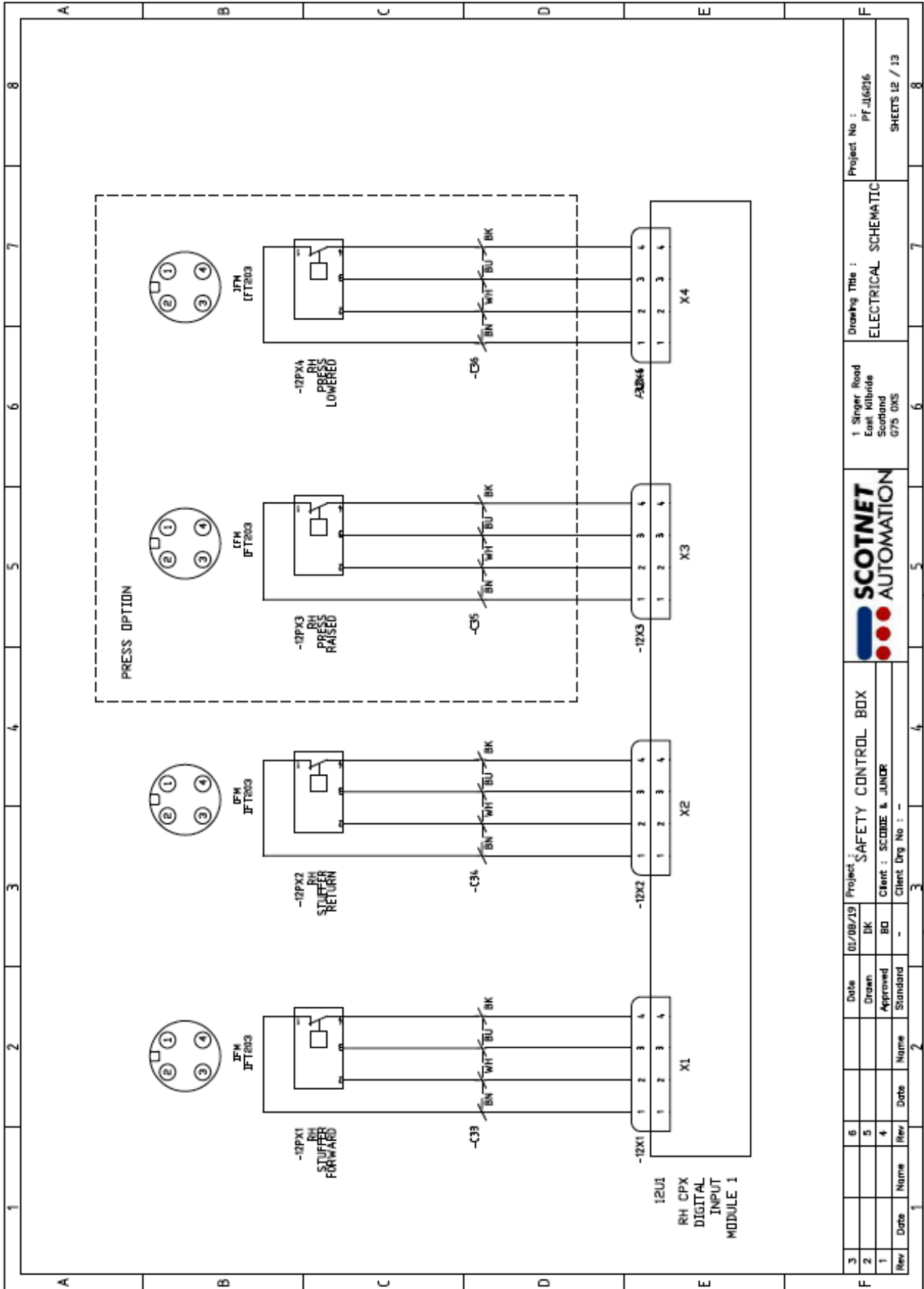

Project No : PF\_J6056  
 SHEETS 12 / 13

Drawing Title :  
 ELECTRICAL SCHEMATIC

1 Singer Road  
 East Kilbride  
 Scotland  
 G75 0XS



Project : SAFETY CONTROL BOX  
 Client : SCOBEE & JUNIOR  
 Client Drg No : -

Rev	Date	Name	Rev	Date	Name
3			6		
2			5		
1			4		
			3		

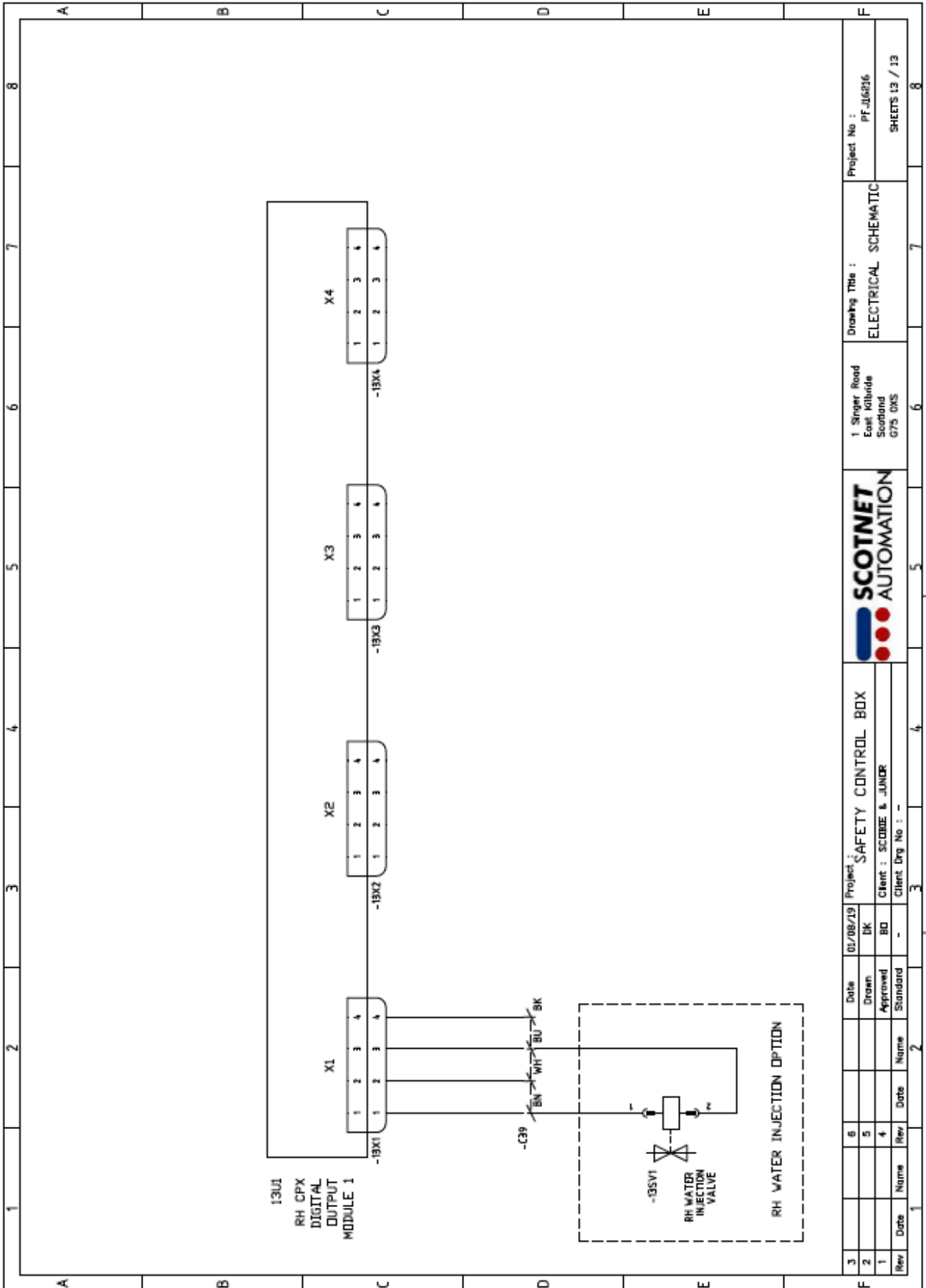

3		6	Date	01/08/19	Project	SAFETY CONTROL BOX		1 Singer Road East Kilbride Scotland G75 0XS	Drawing Title : ELECTRICAL SCHEMATIC	Project No : PF-J6626
2		5	Drawn	UK						
1		4	Approved	BO	Client	SCOBIE & JUNDER				
Rev	Date	Name	Rev	Date	Name	Client Drg No				